

LED Beacon Light

Twirl-Lux

Application:	Motor Vehicles	Police, Ambulance, Fire Service, Military, Cleaning Department, Construction machines , Garbage Disposal
	Industry	Machine light, Security system, Alarm system
	Navigation	Port marking, Boat lighting, Storm warning
	Road works	SOS-telephone, Tunnel Exit Signs
	Railways	Tunnel Exit, Train warning lights

Benefits:	5 different colours available (blue, yellow, white, red, green)
	18 powerful 2.5Watt LED's
	16 different flashing methods, street-legal according ECE65
	No moving parts inside , means no abrasion
	E-approval (blue) E14 00 0002 / (yellow) E14 00 0003



Twirl-Lux

Beacon with Flat Base ISO

- Operating temperature -40°C ~+60°C
- Protection IP56
- 12-32VDC / max. 4.2A (peak)



Part-Number	Colour	Voltage DC
200 08 000	blue	12-32V
200 08 010	yellow	12-32V
200 08 020	red	12-32V
200 08 030	green	12-32V
200 08 040	white	12-32V

Drawing

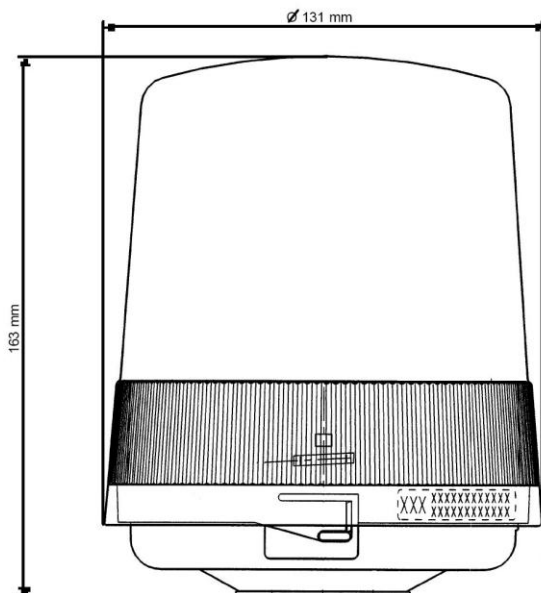

Mounting hole

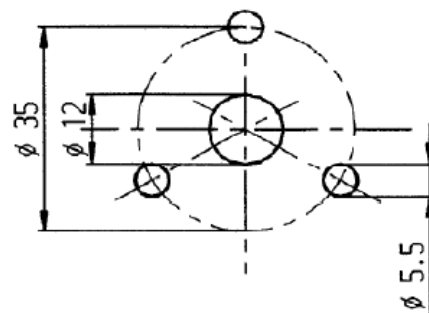

- All dimensions are in millimetres.
- Tolerance is $\pm 0.25\text{mm}$ unless otherwise specified.
- Specifications are subject to change without notice

Twirl-Lux

Beacon with Flat Base DIN

- Operating temperature -40°C ~+60°C
- Protection IP56
- 12-32VDC / max. 4.2A (peak)



Part-Number	Colour	Voltage DC
200 08 001	blue	12-32V
200 08 011	yellow	12-32V
200 08 021	red	12-32V
200 08 031	green	12-32V
200 08 041	white	12-32V

Drawing

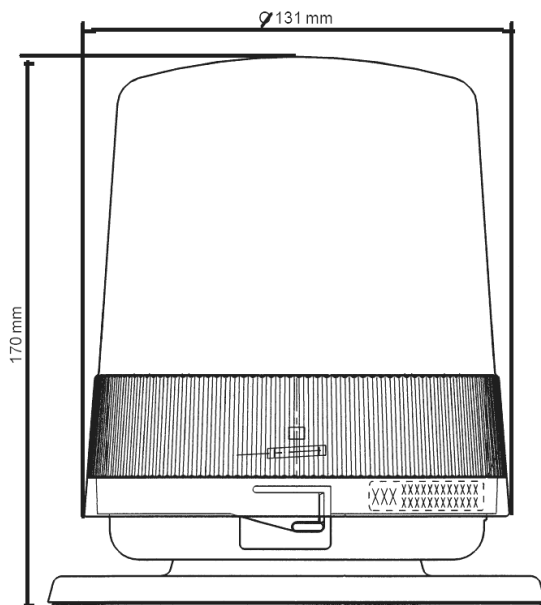

Mounting hole

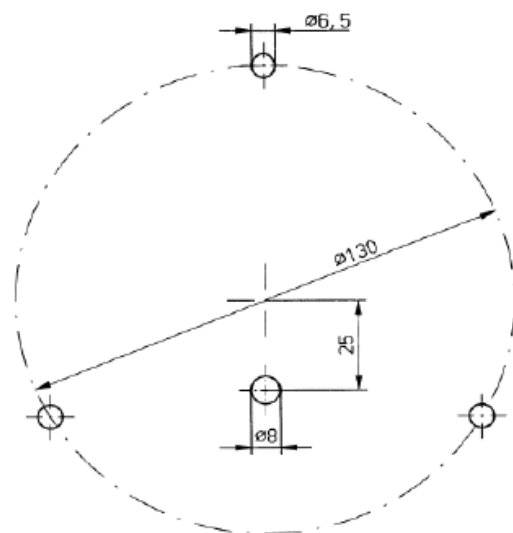

- All dimensions are in millimetres.
- Tolerance is $\pm 0.25\text{mm}$ unless otherwise specified.
- Specifications are subject to change without notice

Twirl-Lux

Beacon with insert base

- Operating temperature -40°C ~+60°C
- Protection IP56
- 12-32VDC / max. 4.2A (peak)



Part-Number	Colour	Voltage DC
200 08 002	blue	12-32V
200 08 012	yellow	12-32V
200 08 022	red	12-32V
200 08 032	green	12-32V
200 08 042	white	12-32V

Drawing

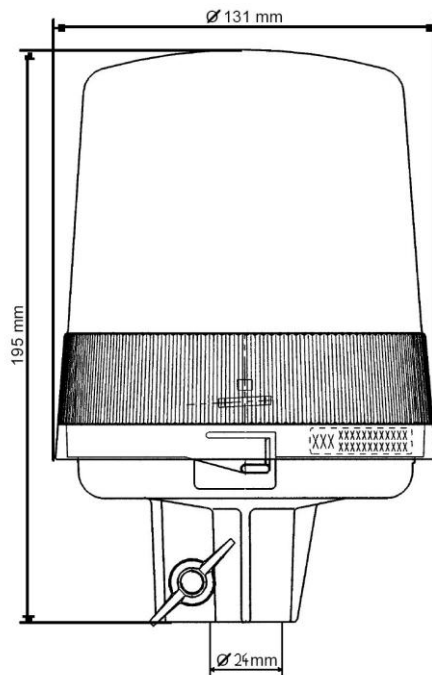

- All dimensions are in millimetres.
- Tolerance is ± 0.25 mm unless otherwise specified.
- Specifications are subject to change without notice

Twirl-Lux

Beacon with magnet base

- Operating temperature -40°C ~+60°C
- Protection IP56
- 12-32VDC / max. 4.2A (peak)



Part-Number	Colour	Voltage DC
200 08 003	blue	12-32V
200 08 013	yellow	12-32V
200 08 023	red	12-32V
200 08 033	green	12-32V
200 08 043	white	12-32V

Drawing

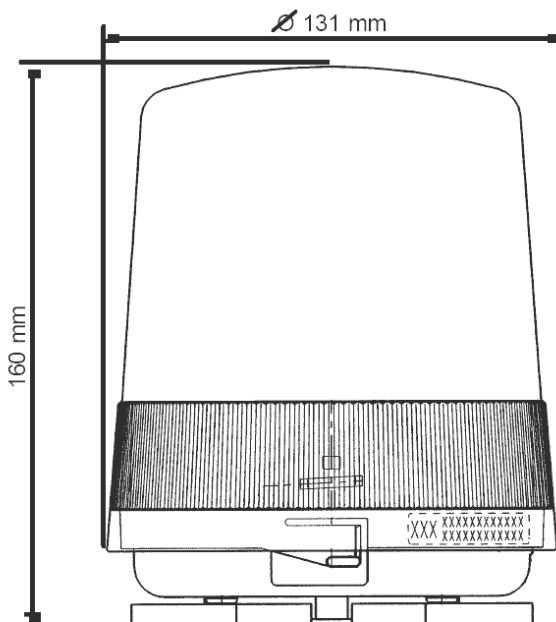

- All dimensions are in millimetres.
- Tolerance is $\pm 0.25\text{mm}$ unless otherwise specified.
- Specifications are subject to change without notice

Twirl-Lux

Wall holder

- Compatible to „Flat base ISO“

Part-Number	Description
200 08 116	Wall Holder



Drawing

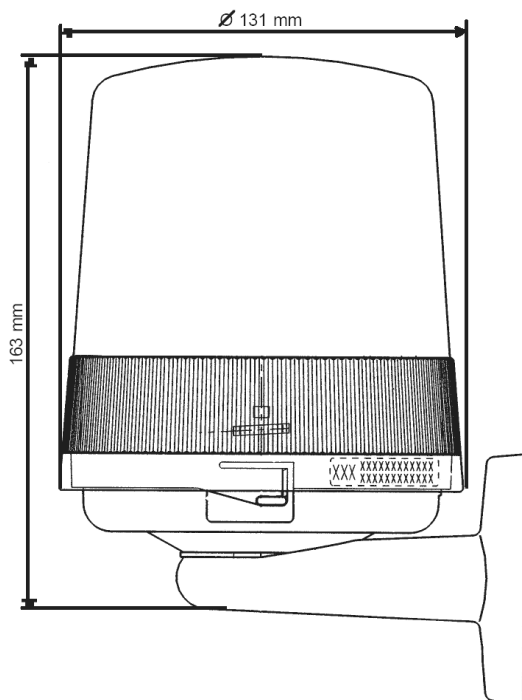

Mounting hole

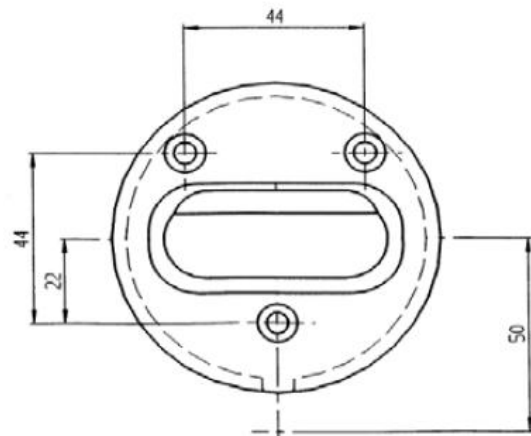

- All dimensions are in millimetres.
- Tolerance is ± 0.25 mm unless otherwise specified.
- Specifications are subject to change without notice

Spare parts

Twirl-Lux

Caps

Part-Number	Description
200 08 117	Cap light-blue
200 08 109	Cap yellow
200 08 110	Cap green
200 08 111	Cap transparent
200 08 112	Cap red



O-Ring gasket

Part-Number	Description
200 08 107	O-Ring gasket

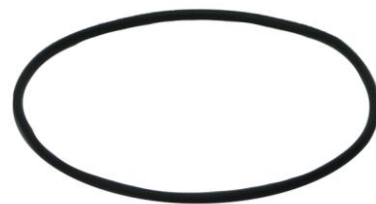

ISO base part

Part-Number	Description
200 08 106	Flat base ISO



DIN base part

Part-Number	Description
200 08 108	Flat base DIN



Sealing gasket to flat base DIN

Part-Number	Description
200 08 114	Sealing gasket



Spare parts

Twirl-Lux

Magnet base part

Part-Number	Description
200 08 113	Magnet base



Insert base part

Part-Number	Description
200 08 115	Insert base



Light module

Part-Number	Description
200 08 091	Light module blue for blue beacon
200 08 092	Light module natural-white for yellow beacon
200 08 093	Light module red for red beacon
200 08 094	Light module green for green beacon
200 08 095	Light module cold-white for transparent beacon

